

19. Schaftschneidrad Kerbverzahnung SAE

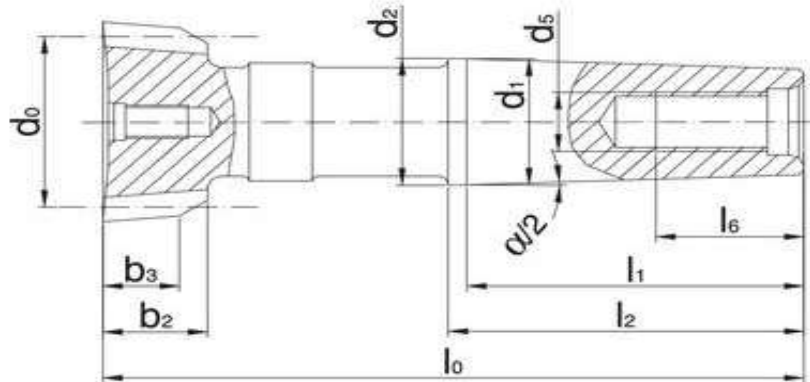

Modul	Zähnezahl Z	Nenndruch- messer d_o	Verzahnungs- breite l_o-l_2	Morse- kegel	Bemerkung
0.411	28	13	30	2	5/8" Z=36
0.45	30	13	30	2	5/8" Z=36
	32	18	35	2	1" Z=48